



SONDEX

SWC136 Condenser Plate Heat Exchanger

The SWC136 Sondex Condenser plate heat exchanger is specially developed for condensing of low pressure vapour.

The plate is designed as a semi welded cassette, with a welded channel for the condensing side. On the medium side there is a traditional plate heat exchanger gasket. The unique plate design makes it possible to utilize almost the whole plate area as heat transmission area.

This plate is designed in two different plate patterns on the welded side. For dirty and fibre products, the plate is designed with 20 mm wide gap plate pattern. For clean products the plate pattern is on both the welded side as well as the medium side a herring bone pattern.

The plate has a combination of two different plate patterns heights. This makes it optimal for keeping a low pressure drop on the welded side and at the same time a high turbulence on the medium side. This results in a high heat transmission.

Installation

The DN800 / 32" Vapour connection makes it possible to cover many duties in a single pass solution. All connections will thus be on the head of the heat exchanger, which is of big advantage during service work. The plate pattern and inlet area are also designed for CIP cleaning making the service of the PHE easy.

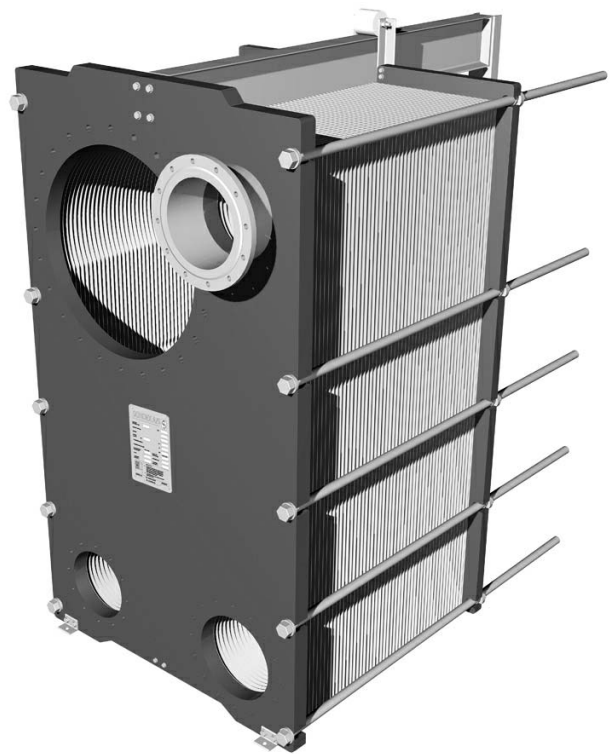

Plates:

Standard material:

AISI 304 and AISI 316

Not standard: 254 SMO, Hastelloy and other pressable materials.

Gaskets:

The gasket is the unique "Sonder lock" gasket. The "Sonder lock" gasket locks the plates together with strong rubber buttons, so that the plates are strongly guided during the assembling of the plate heat exchanger.

Standard material: Nitrile and EPDM.

Not standard: Viton.

Technical Information:

Frame:

Painted frame with placement of clamping bolts on the frame edge.
Standard colour: Blue RAL 5010
can be made in other colours.

Working pressure:

The frames are designed to the following working pressure
0,6 MPa /1,0 MPa

Construction Norm:

According to TÜV Norm A-D
"Merkblätter" B5 and PED
97/23/EC

Connections:

Inlet product side (F1) DN800 / 32"
Outlet (F3) DN350 / 14"
Flange according to all known standards.
Inlet medium side (F4) DN300 / 12"
Outlet (F2) DN300 / 12"
Flange according to all known standards.
In carbon steel, rubber lined or stainless steel.

Extra Equipment:

Screen plate in stainless steel.
Insulation jacket.
Spanner.
Foundation feet for frame.

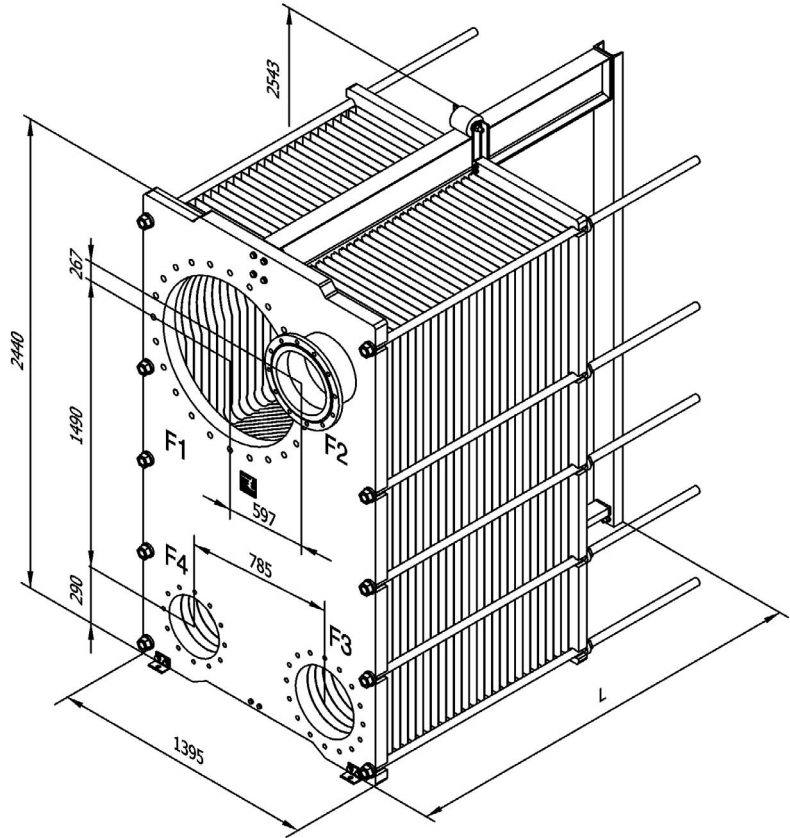

SONDEX A/S • JERNET 9 • DK-6000 KOLDING • DENMARK

SONDEX

Phone +45 76 30 61 00 • Telefax +45 75 53 89 68 / +45 75 50 50 19